

Precision 1 A regulators

Features

- Output current in excess of 1 A
- Output voltages of 5; 6; 8; 9; 12; 15; 24 V
- Thermal overload protection
- Output transition SOA protection
- 2 % Output voltage tolerance
- Guaranteed in extended temperature range

Description

The L78xxAB L78xxAC series of three terminal positive regulators are available in TO-220, TO-220FP, and D²PAK packages and several fixed output voltages, making it useful in a wide range of applications. These regulators can provide local on-card regulation, eliminating the distribution problem associated with single point regulation. Each type employs internal current limiting, thermal shut-down and safe area protection, making it essentially indestructible. If adequate heat sinking is provided, they can deliver over 1 A output current, although designed primarily as fixed voltage regulators, these devices can be used with external components to obtain adjustable voltage and currents.

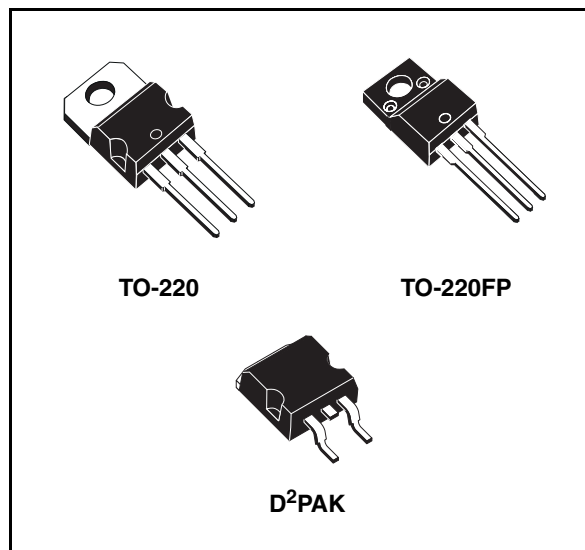

Table 1. Device summary

Order codes	
L7805AB	L7809AC
L7805AC	L7812AB
L7806AB	L7812AC
L7806AC	L7815AB
L7808AB	L7815AC
L7808AC	L7824AB
L7809AB	L7824AC

3 Maximum ratings

Table 2. Absolute maximum ratings

Symbol	Parameter		Value	Unit
V_I	DC input voltage	for $V_O = 5$ to $18V$	35	V
		for $V_O = 20, 24V$	40	
I_O	Output current		Internally limited	mA
P_D	Power dissipation		Internally limited	mW
T_{STG}	Storage temperature range		-65 to 150	°C
T_{OP}	Operating junction temperature range	for L7800AC	0 to 150	°C
		for L7800AB	-40 to 125	

Note: Absolute maximum ratings are those values beyond which damage to the device may occur. Functional operation under these condition is not implied.

Table 3. Thermal data

Symbol	Parameter	TO-220	TO-220FP	D ² PAK	Unit
R_{thJC}	Thermal resistance junction-case	3	5	3	°C/W
R_{thJA}	Thermal resistance junction-ambient	50	60	62.5	°C/W

Figure 4. Application circuit

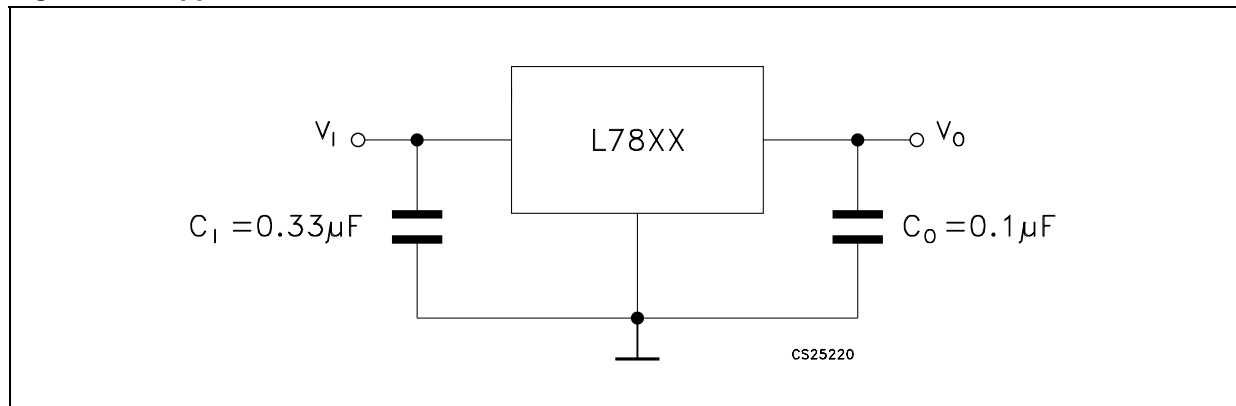

5 Electrical characteristics

Table 4. Electrical characteristics of L7805A ($V_I = 10\text{ V}$, $I_O = 1\text{ A}$, $T_J = 0\text{ to }150\text{ °C}$ (L7805AC), $T_J = -40\text{ to }125\text{ °C}$ (L7805AB), unless otherwise specified)

Symbol	Parameter	Test conditions	Min.	Typ.	Max.	Unit
V_O	Output voltage	$T_J = 25\text{ °C}$	4.9	5	5.1	V
V_O	Output voltage	$I_O = 5\text{ mA to }1\text{ A}$, $P_O \leq 15\text{ W}$ $V_I = 7.5\text{ to }20\text{ V}$	4.8	5	5.2	V
$\Delta V_O^{(1)}$	Line regulation	$V_I = 7.5\text{ to }25\text{ V}$, $I_O = 500\text{ mA}$		7	50	mV
		$V_I = 8\text{ to }12\text{ V}$		10	50	mV
		$V_I = 8\text{ to }12\text{ V}$, $T_J = 25\text{ °C}$		2	25	mV
		$V_I = 7.3\text{ to }20\text{ V}$, $T_J = 25\text{ °C}$		7	50	mV
$\Delta V_O^{(*)}$	Load regulation	$I_O = 5\text{ mA to }1\text{ A}$		25	100	mV
		$I_O = 5\text{ mA to }1.5\text{ A}$, $T_J = 25\text{ °C}$		30	100	V
		$I_O = 250\text{ to }750\text{ mA}$		8	50	V
I_q	Quiescent current	$T_J = 25\text{ °C}$		4.3	6	mA
					6	mA
ΔI_q	Quiescent current change	$V_I = 8\text{ to }25\text{ V}$, $I_O = 500\text{ mA}$			0.8	mA
		$V_I = 7.5\text{ to }20\text{ V}$, $T_J = 25\text{ °C}$			0.8	mA
		$I_O = 5\text{ mA to }1\text{ A}$			0.5	mA
SVR	Supply voltage rejection	$V_I = 8\text{ to }18\text{ V}$, $f = 120\text{ Hz}$, $I_O = 500\text{ mA}$		68		dB
V_d	Dropout voltage	$I_O = 1\text{ A}$, $T_J = 25\text{ °C}$		2		V
eN	Output noise voltage	$T_A = 25\text{ °C}$, $B = 10\text{ Hz to }100\text{ kHz}$		10		$\mu\text{V}/V_O$
R_O	Output resistance	$f = 1\text{ kHz}$		17		$\text{m}\Omega$
I_{sc}	Short circuit current	$V_I = 35\text{ V}$, $T_A = 25\text{ °C}$		0.2		A
I_{scp}	Short circuit peak current	$T_J = 25\text{ °C}$		2.2		A
$\Delta V_O/\Delta T$	Output voltage drift			-1.1		$\text{mV}/\text{°C}$

1. Load and line regulation are specified at constant junction temperature. Changes in V_O due to heating effects must be taken into account separately. Pulse testing with low duty cycle is used.

TO-220 mechanical data

Dim.	mm.			inch.		
	Min.	Typ.	Max.	Min.	Typ.	Max.
A	4.40		4.60	0.173		0.181
C	1.23		1.32	0.048		0.051
D	2.40		2.72	0.094		0.107
D1		1.27			0.050	
E	0.49		0.70	0.019		0.027
F	0.61		0.88	0.024		0.034
F1	1.14		1.70	0.044		0.067
F2	1.14		1.70	0.044		0.067
G	4.95		5.15	0.194		0.203
G1	2.4		2.7	0.094		0.106
H2	10.0		10.40	0.393		0.409
L2		16.4			0.645	
L4	13.0		14.0	0.511		0.551
L5	2.65		2.95	0.104		0.116
L6	15.25		15.75	0.600		0.620
L7	6.2		6.6	0.244		0.260
L9	3.5		3.93	0.137		0.154
DIA.	3.75		3.85	0.147		0.151

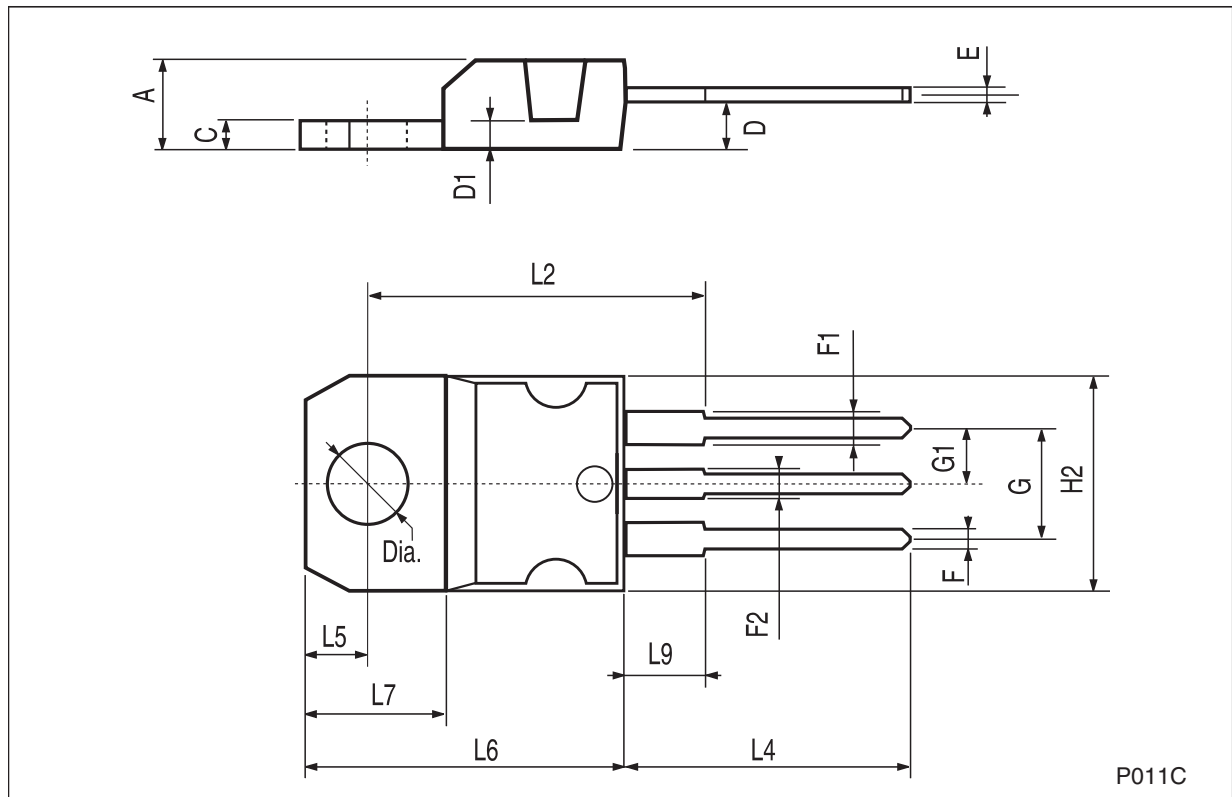

8 Order codes

Table 13. Order codes

Part number	Packaging			Output voltage
	TO-220	TO-220FP	D ² PAK	
L7805AB	L7805ABV	L7805ABP	L7805ABD2T-TR	5 V
L7805AC	L7805ACV	L7805ACP	L7805ACD2T-TR	5 V
L7806AB	L7806ABV		L7806ABD2T-TR	6 V
L7806AC	L7806ACV		L7806ACD2T-TR	6 V
L7808AB	L7808ABV		L7808ABD2T-TR	8 V
L7808AC	L7808ACV		L7808ACD2T-TR	8 V
L7809AB	L7809ABV		L7809ABD2T-TR	9 V
L7809AC	L7809ACV		L7809ACD2T-TR	9 V
L7812AB	L7812ABV		L7812ABD2T-TR	12 V
L7812AC	L7812ACV		L7812ACD2T-TR	12 V
L7815AB	L7815ABV		L7815ABD2T-TR	15 V
L7815AC	L7815ACV		L7815ACD2T-TR	15 V
L7824AB	L7824ABV		L7824ABD2T-TR	24 V
L7824AC	L7824ACV			24 V